

General Description

The LTA199 series of bidirectional zero-drift current sense amplifier can sense drops across shunts at common-mode voltages from -0.3V to 30V , independent of the supply voltage. Unidirectional operation allows the LTA199 series to measure currents through a resistive shunt in one direction, while bidirectional operation allows the device to measure currents through a resistive shunt in two directions. The low offset of the zero-drift architecture enables current sensing with maximum drops across the shunt as low as 10mV full-scale.

The LTA199 series operates from a single $+2.7\text{V}$ to $+30\text{V}$ power supply, drawing a maximum of $100\mu\text{A}$ of supply current. The device is specified from -40°C to $+105^\circ\text{C}$, and offered in SC70-6L and TQFN-10L packages.

Features and Benefits

- Wide common-mode range: -0.3V to 30V
- Maximum $\pm 150\mu\text{V}$ Offset voltage (LTA199G1) at $V_{\text{cm}}=0\text{V}$
- Accuracy
 - Maximum $\pm 1\%$ Gain Error
 - Maximum $1\mu\text{V}/^\circ\text{C}$ Offset Drift
 - Maximum $10\text{ppm}/^\circ\text{C}$ Gain Drift
- Choice of Gains:
 - LTA199G1: $50\text{V}/\text{V}$
 - LTA199G2: $100\text{V}/\text{V}$
 - LTA199G3: $200\text{V}/\text{V}$
- Quiescent Current: Maximum $250\mu\text{A}$
- Package: SC70-6L, TQFN-10L(Contact with sales if needed)

Applications

- Power Management
- Battery Chargers
- Electrical Cigarette
- Smart Phones and Tablets
- Notebook Computers
- Telecom Equipments
- Welding Equipments

Block Diagram and Pin Configuration (Top View)

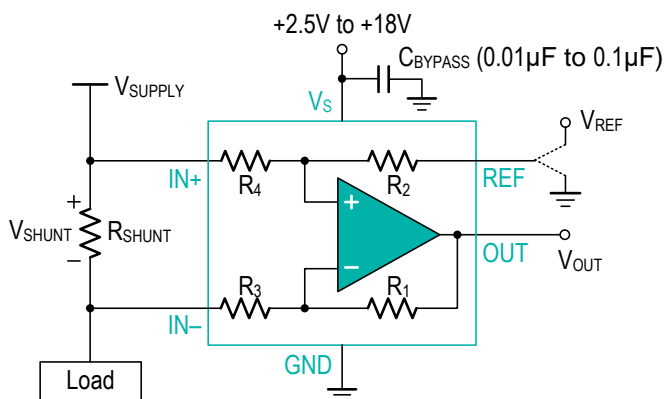

High-side Sensing Application

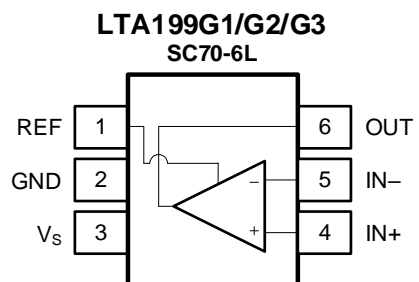

Pin Description

Symbol	Description
IN-	Inverting input of the amplifier.
IN+	Non-inverting input of the amplifier.
OUT	Amplifier output. The voltage range extends to within millivolt of each supply rail.
REF	Reference voltage
V _S	Positive power supply. Typically, the voltage is from +2.7V to +30V. A bypass capacitor of 0.1μF as close to the part as possible should be used between power supply pin and ground pin.
GND	Negative power supply.

Ordering Information

Orderable Type Number	Package Name	Package Quantity	Eco Class ⁽¹⁾	Marking Code
LTA199G1XC6/R6	SC70-6L	3 000	Green (RoHS & no Sb/Br)	9H1
LTA199G1XF10/R10	Thin QFN-10L	5 000	Green (RoHS & no Sb/Br)	9H1
LTA199G2XC6/R6	SC70-6L	3 000	Green (RoHS & no Sb/Br)	9H2
LTA199G2XF10/R10	Thin QFN-10L	5 000	Green (RoHS & no Sb/Br)	9H2
LTA199G3XC6/R6	SC70-6L	3 000	Green (RoHS & no Sb/Br)	9H3
LTA199G3XF10/R10	Thin QFN-10L	5 000	Green (RoHS & no Sb/Br)	9H3

(1) *Eco Class - The planned eco-friendly classification: Pb-Free (RoHS) or Green (RoHS & Halogen Free).*

(2) *Please contact to your Linearin representative for the latest availability information and product content details.*

Limiting Value

In accordance with the Absolute Maximum Rating System (IEC 60134).

Parameter	Absolute Maximum Rating
Supply Voltage, V _S to GND	+30V
Analog Input (IN+, IN-), Differential (V _{IN+} - V _{IN-})	-30V to +30V
Analog Input (IN+, IN-), Common-Mode	(GND - 0.3V) to +30V
REF Input	(GND - 0.3V) to (V ₊ + 0.3V)
Output	(GND - 0.3V) to (V ₊ + 0.3V)
Input Current Into All Pins	5mA
Storage Temperature Range	-65°C to +150°C
Junction Temperature	150°C
Lead Temperature Range (Soldering 10 sec)	260°C

ESD Rating

Parameter	Item	Value	Unit
Electrostatic Discharge Voltage	Human body model (HBM), per ESDA/JEDEC JS-001-2023 ⁽¹⁾	± 3 000	V
	Charged device model (CDM), per ESDA/JEDEC JS-002-2022 ⁽²⁾	± 2 000	

(1) JEDEC document JEP155 states that 500-V HBM allows safe manufacturing with a standard ESD control process.

(2) JEDEC document JEP157 states that 250-V CDM allows safe manufacturing with a standard ESD control process.

Electrical Characteristics

$T_A = +25^\circ\text{C}$, $V_S = +5.0\text{V}$, $V_{IN+} = 12\text{V}$, $V_{SENSE} = V_{IN+} - V_{IN-}$ and $V_{REF} = V_S/2$, unless otherwise noted.
Boldface limits apply over the specified temperature range, $T_A = -40$ to $+105^\circ\text{C}$.

Symbol	Parameter	Conditions	Min.	Typ.	Max.	Unit
INPUT CHARACTERISTICS						
V_{OS}	Referred-to-input offset voltage	$V_{SENSE} = 0\text{mV}$		± 25	± 150	μV
$V_{OS\ TC}$	Offset voltage drift	over Temperature		0.4	1	$\mu\text{V}/^\circ\text{C}$
I_B	Input bias current	$V_{SENSE} = 0\text{mV}$		28		μA
I_{OS}	Input offset current	$V_{SENSE} = 0\text{mV}$		± 0.4		μA
V_{CM}	Common-mode input voltage range		-0.3		30	V
CMRR	Common-mode rejection ratio	$V_{IN+} = 0\text{V to } +26\text{V}$, $V_{SENSE} = 0\text{mV}$	90	105		dB
OUTPUT CHARACTERISTICS						
G	Gain	LTA199G1		50		V/V
		LTA199G2		100		
		LTA199G3		200		
E_G	Gain error	$V_{SENSE} = -5\text{mV to } 5\text{mV}$		± 0.1	± 1	%
$E_G\ TC$	Gain error drift	over Temperature		3	10	ppm/ $^\circ\text{C}$
	Nonlinearity Error	$V_{SENSE} = -5\text{mV to } 5\text{mV}$		± 0.01		%
C_L	Maximum Capacitive Load	No sustained oscillation		1		nF
V_{OH}	Swing to V_S rail	$R_L = 10\text{k}\Omega$ to GND		$V_S - 30$		mV
V_{OL}	Swing to GND			$V_{GND} + 2$		
DYNAMIC PERFORMANCE						
BW	Bandwidth	LTA199G1, $C_{LOAD} = 10\text{pF}$		120		kHz
		LTA199G2, $C_{LOAD} = 10\text{pF}$		50		
SR	Slew rate			1.5		V/ μs
NOISE PERFORMANCE						
e_n	Voltage noise density	Referred-to-input		30		nV/ $\sqrt{\text{Hz}}$
POWER SUPPLY						
V_S	Operating supply voltage		+3		+30	V
PSR	Input vs power supply	$V_S = +2.5\text{V to } +18\text{V}$, $V_{IN+} = +18\text{V}$, $V_{SENSE} = 0\text{mV}$		± 4	± 20	$\mu\text{V}/\text{V}$
I_Q	Quiescent current over Temperature	$V_{SENSE} = 0\text{mV}$		180	250 290	μA
THERMAL CHARACTERISTICS						
T_A	Operating temperature		-40		+125	$^\circ\text{C}$
θ_{JA}	Package Thermal Resistance	SC70-6L		250		$^\circ\text{C}/\text{W}$
		TQFN-10L		80		

Typical Performance Characteristics

At $T_A = +25^\circ\text{C}$, $V_S = +5.0\text{V}$, $V_{IN+} = 12\text{V}$, and $V_{REF} = V_S/2$, unless otherwise noted.

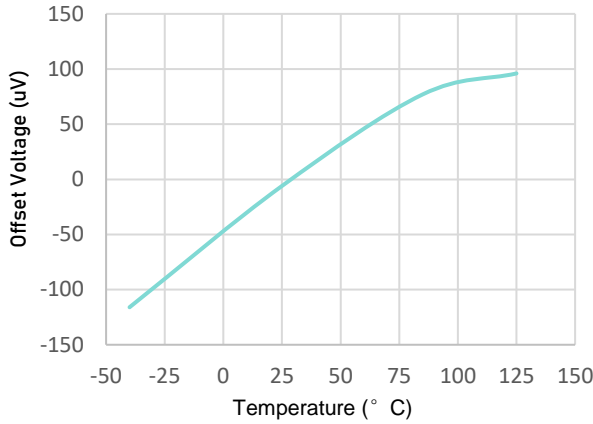

Offset Voltage vs. Temperature

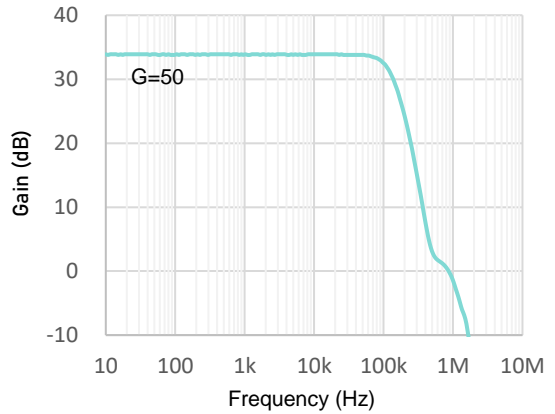

Gain vs. Frequency

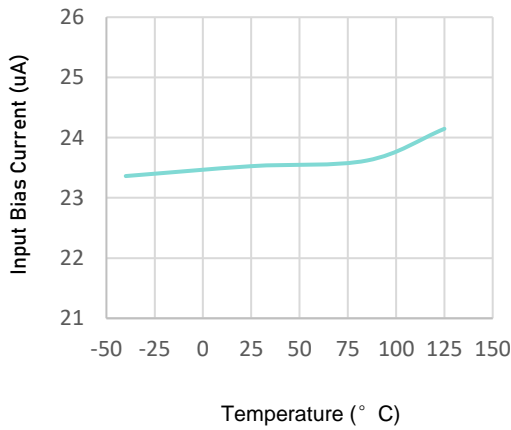

Input Bias Current vs. Temperature

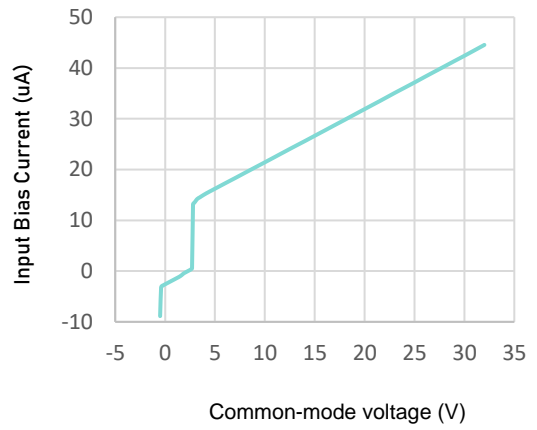

Input Bias Current vs. Common-mode voltage with power supply=5V

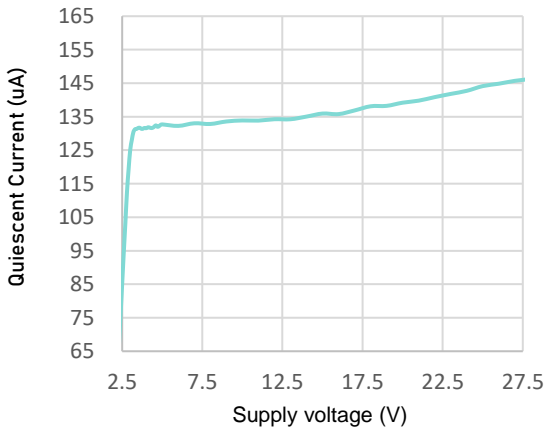

Quiescent Current vs. Supply Voltage

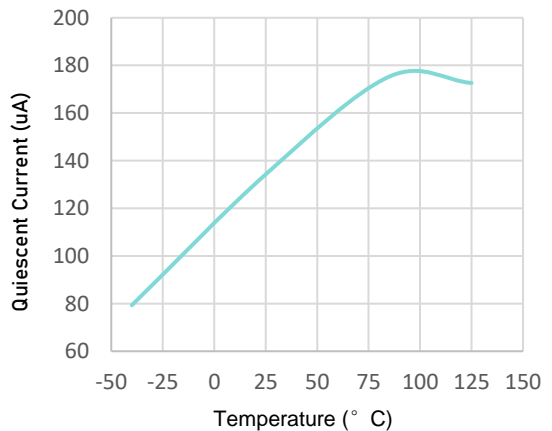

Quiescent Current vs. Temperature

CAUTION: These devices are sensitive to electrostatic discharge; follow proper IC Handling Procedures.
Linearin and designs are registered trademarks of Linearin Technology Corporation.
© Copyright Linearin Technology Corporation. All Rights Reserved.
All other trademarks mentioned are the property of their respective owners.

Typical Performance Characteristics (continued)

At $T_A = +25^\circ\text{C}$, $V_S = +5.0\text{V}$, $V_{IN+} = 12\text{V}$, and $V_{REF} = V_S/2$, unless otherwise noted.

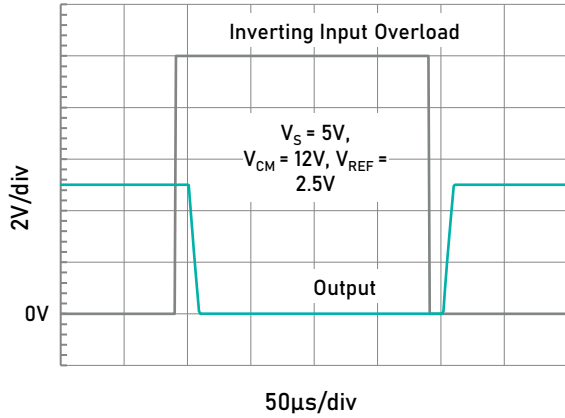

Inverting Differential Input Overload

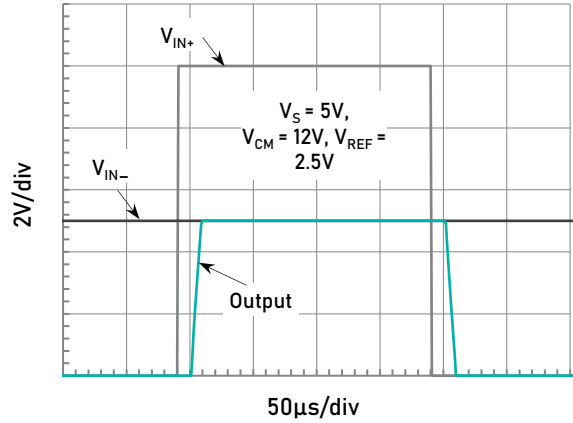

Noninverting Differential Input Overload

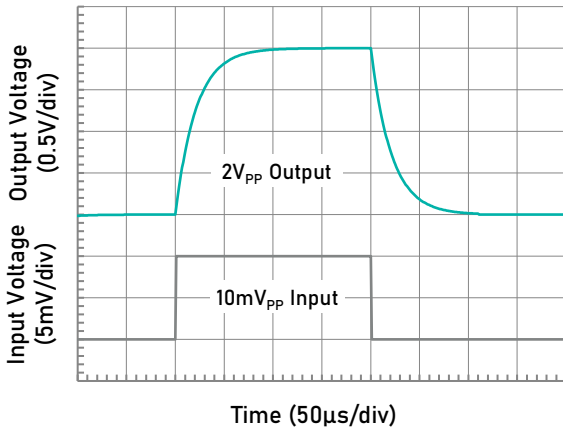

Step Response (10mV_{pp} Input Step)

Application Notes

BASIC CONNECTIONS

Figure 1 shows the basic connections for the LTA199. The input pins, IN+ and IN-, should be connected as closely as possible to the shunt resistor to minimize any resistance in series with the shunt resistance.

Power-supply bypass capacitors are required for stability. Applications with noisy or high-impedance power supplies may require additional decoupling capacitors to reject power-supply noise. Connect bypass capacitors close to the device pins.

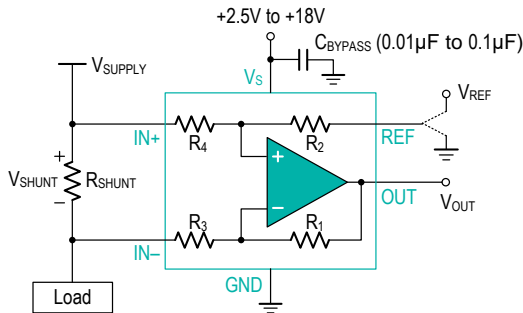

High-side Sensing Application

Figure 1. Typical Application

POWER SUPPLY

The input circuitry of the LTA199 can accurately measure beyond its power-supply voltage, V_S . For example, the V_S power supply can be 5V, whereas the load power-supply voltage can be as high as +18V. However, the output voltage range of the OUT terminal is limited by the voltages on the power-supply pin. Note also that the LTA199 can withstand the full $-0.3V$ to $+30V$ range in the input pins, regardless of whether the device has power applied or not.

SELECTING R_S

The zero-drift offset performance of the LTA199 offers several benefits. Most often, the primary advantage of the low offset characteristic enables lower full-scale drops across the shunt. For example, non-zero-drift current sense amplifiers typically require a full-scale range of 100mV.

The LTA199 of current sense amplifier gives equivalent accuracy at a full-scale range on the order of 10mV. This accuracy reduces shunt dissipation by an order of magnitude with many additional benefits.

Alternatively, there are applications that must measure current over a wide dynamic range that can take advantage of the low offset on the low end of the measurement. Most often, these applications can use the lower gain of 100 to accommodate larger shunt drops on the upper end of the scale.

UNIDIRECTIONAL OPERATION

Unidirectional operation allows the LTA199 to measure currents through a resistive shunt in one direction. The most frequent case of unidirectional operation sets the output at ground by connecting the REF pin to ground. In unidirectional applications where the highest possible accuracy is desirable at very low inputs, bias the REF pin to a convenient value above 50mV to get the device output swing into the linear range for zero inputs.

A less frequent case of unipolar output biasing is to bias the

output by connecting the REF pin to the supply; in this case, the quiescent output for zero input is at quiescent supply. This configuration would only respond to negative currents (inverted voltage polarity at the device input).

BIDIRECTIONAL OPERATION

Bidirectional operation allows the LTA199 to measure currents through a resistive shunt in two directions. In this case, the output can be set anywhere within the limits of what the reference inputs allow (that is, between 0V to $V+$). Typically, it is set at half-scale for equal range in both directions. In some cases, however, it is set at a voltage other than half-scale when the bidirectional current is nonsymmetrical.

The quiescent output voltage is set by applying voltage to the reference input. Under zero differential input conditions the output assumes the same voltage that is applied to the reference input.

INPUT FILTERING

An obvious and straightforward filtering location is at the device output. However, this location negates the advantage of the low output impedance of the internal buffer. The only other filtering option is at the device input pins. This location, though, does require consideration of the $\pm 30\%$ tolerance of the internal resistances. Figure 2 shows a filter placed at the inputs pins.

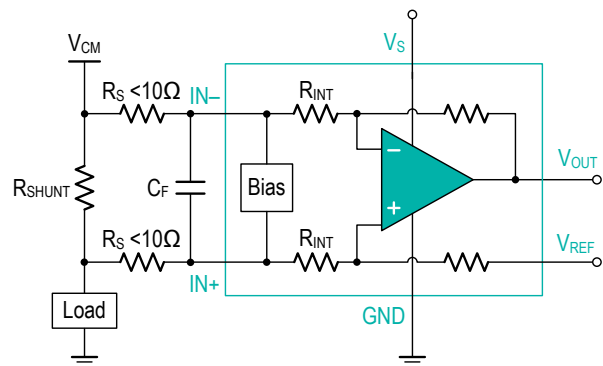

Figure 2. Filter at Input Pins

The addition of external series resistance, however, creates an additional error in the measurement so the value of these series resistors should be kept to 10Ω or less if possible to reduce impact to accuracy. The internal bias network shown in Figure 2 present at the input pins creates a mismatch in input bias currents when a differential voltage is applied between the input pins. If additional external series filter resistors are added to the circuit, the mismatch in bias currents results in a mismatch of voltage drops across the filter resistors. This mismatch creates a differential error voltage that subtracts from the voltage developed at the shunt resistor. This error results in a voltage at the device input pins that is different than the voltage developed across the shunt resistor. Without the additional series resistance, the mismatch in input bias currents has little effect on device operation. The amount of error these external filter resistor add to the measurement can be calculated using Equation 2 where the gain error factor is calculated using Equation 1.

The amount of variance in the differential voltage present at the device input relative to the voltage developed at the

Application Notes (continued)

shunt resistor is based both on the external series resistance value as well as the internal input resistors, R_{INT} as shown in Figure 2. The reduction of the shunt voltage reaching the device input pins appears as a gain error when comparing the output voltage relative to the voltage across the shunt resistor. A factor can be calculated to determine the amount of gain error that is introduced by the addition of external series resistance. The equation used to calculate the expected deviation from the shunt voltage to what is seen at the device input pins is given in Equation 1:

$$\text{Gain Error Factor} = \frac{1250 \times R_{INT}}{1250 \times R_S + 1250 \times R_{INT} + R_S \times R_{INT}}$$

where:

R_{INT} is the internal input resistor (R3 and R4, 10k Ω), and R_S is the external series resistance.

The gain error that can be expected from the addition of the external series resistors can then be calculated based on Equation 2:

$$\text{Gain Error (\%)} = 100 - (100 \times \text{Gain Error Factor})$$

For LTA199, a series resistance of 10 Ω results in a gain error factor of 0.991. The corresponding gain error is then calculated using Equation 2, resulting in a gain error of approximately 0.89% solely because of the external 10 Ω series resistors.

Tape and Reel Information

REEL DIMENSIONS

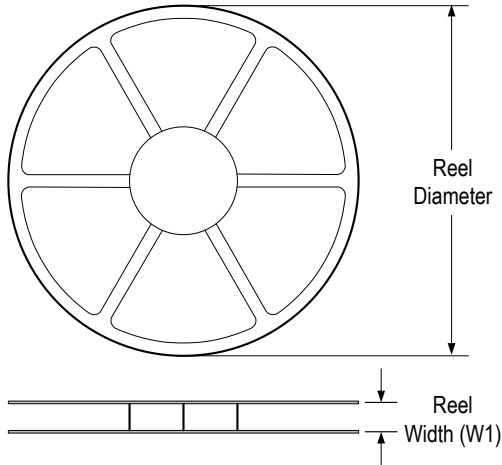

TAPE DIMENSIONS

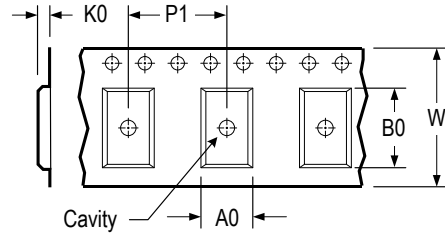

A0	Dimension designed to accommodate the component width
B0	Dimension designed to accommodate the component length
K0	Dimension designed to accommodate the component thickness
W	Overall width of the carrier tape
P1	Pitch between successive cavity centers

QUADRANT ASSIGNMENTS FOR PIN 1 ORIENTATION IN TAPE

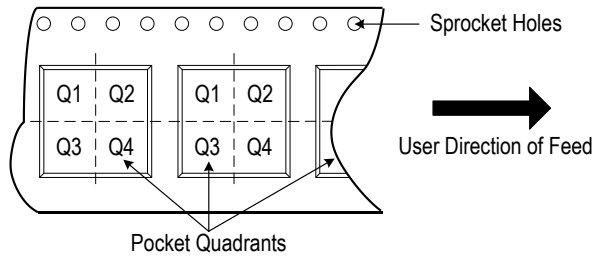

* All dimensions are nominal

Device	Package Type	Pins	SPQ	Reel Diameter (mm)	Reel Width W1 (mm)	A0 (mm)	B0 (mm)	K0 (mm)	P1 (mm)	W (mm)	Pin 1 Quadrant
LTA199G1XC6/R6	SC70	6	3 000	178.0	10.0	4.0	3.5	1.5	4.0	8.0	Q3
LTA199G2XC6/R6	SC70	6	3 000	178.0	10.0	4.0	3.5	1.5	4.0	8.0	Q3
LTA199G3XC6/R6	SC70	6	3 000	178.0	10.0	4.0	3.5	1.5	4.0	8.0	Q3

Package Outlines

DIMENSIONS, SC70-6L(SOT363)

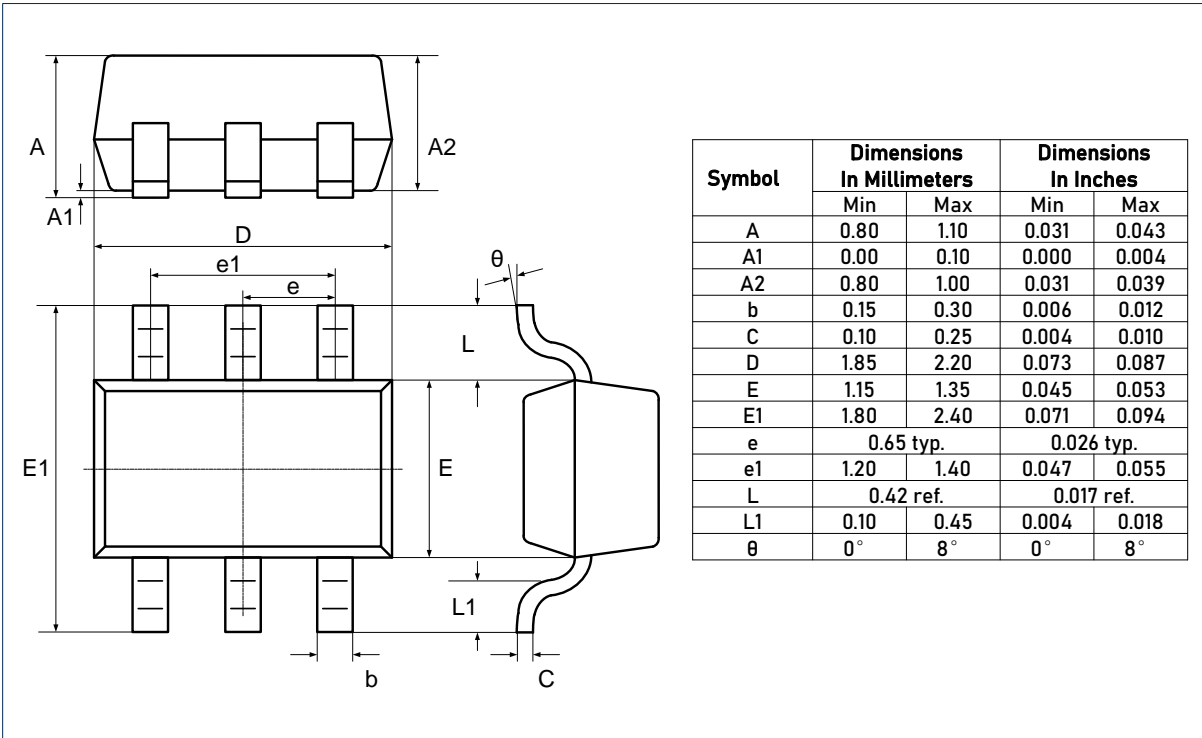

RECOMMENDED SOLDERING FOOTPRINT, SC70-6L (SOT363)

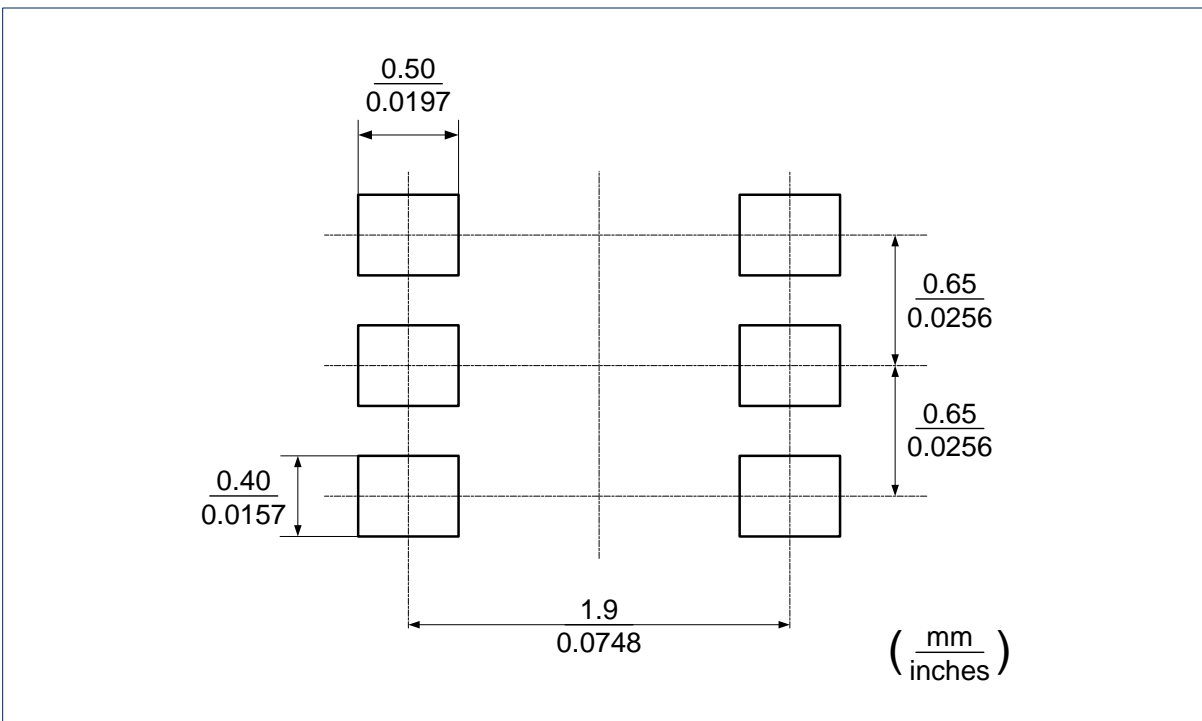

CAUTION: These devices are sensitive to electrostatic discharge; follow proper IC Handling Procedures.
Linearin and designs are registered trademarks of Linearin Technology Corporation.
© Copyright Linearin Technology Corporation. All Rights Reserved.
All other trademarks mentioned are the property of their respective owners.

IMPORTANT NOTICE

Linearin is a global fabless semiconductor company specializing in advanced high-performance high-quality analog/mixed-signal IC products and sensor solutions. The company is devoted to the innovation of high performance, analog-intensive sensor front-end products and modular sensor solutions, applied in multi-market of medical & wearable devices, smart home, sensing of IoT, and intelligent industrial & smart factory (industrie 4.0). Linearin's product families include widely-used standard catalog products, solution-based application specific standard products (ASSPs) and sensor modules that help customers achieve faster time-to-market products. Go to <http://www.linearin.com> for a complete list of Linearin product families.

For additional product information, or full datasheet, please contact with the Linearin's Sales Department or Representatives.